

COATING EQUIPMENT SPEC SHEET
3 COMPONENT PU MACHINE

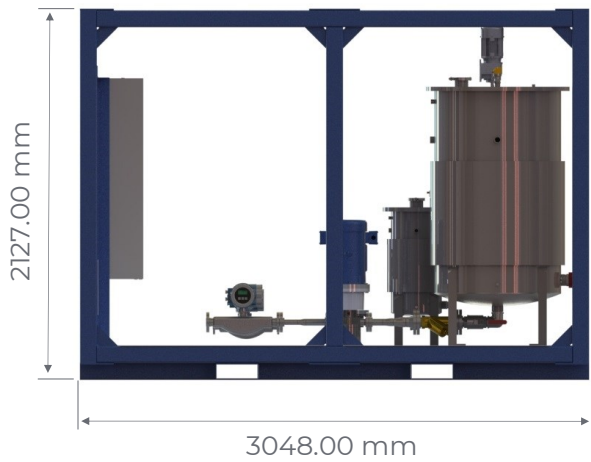

| | | |
|-------------------|-------------------------------|------------------------------|
| Weight | 7716 lbs | 3500 kg |
| Voltage | 400v- 480v 3~ | |
| Amps | 63 A | |
| Tank Size | 2 x 155 gallon, 1 x 12 gallon | 2 x 586 litre , 1 x 45 litre |
| Pump Size | 2 x 27 g/m, 1 x 0.5 g/m | 2 x 104 l/m, 1 x 2 l/m |
| Air Supply | 150 cfm at 116 psi (minimum) | 150 cfm at 8 bar (minimum) |